

A PENNSYLVANIA STATE UNIVERSITY / GENERAL ELECTRIC
GET WAY SPECIAL (GAS) EXPERIMENT

by George Evanisko, Theodore Grosch, Milad Youssef, and Jim Yurack
Faculty Advisor: Professor C. R. Philbrick
Pennsylvania State University, University Park, PA

ABSTRACT

We describe four student designed experiments by the Pennsylvania State University, which are planned for a GAS canister. The four experiments will measure; the effects of radiation on semiconductors, orbital debris impacts, the Space Shuttle's magnetic field, and the photoelectric yield of several different materials. These experiments are the result of the efforts of more than one hundred students.

INTRODUCTION

The GAS program at the Pennsylvania State University was started in January, 1991 with an organizational meeting for all graduate and undergraduate students in Engineering and Science. Students were introduced to the GAS concept and asked to suggest ideas, focused towards a microgravity and space environment, to be flown in the canister. Undergraduate students in a senior level course, Introduction to Space Sciences, were also asked to suggest ideas for experiments. A competition to select the best conceptual design was held during Spring 1992 and was open to all students in the University. Twelve proposals, with ideas ranging from a spaceborne lidar system to making optical lenses in a microgravity environment, were submitted. Professors from the College of Electrical Engineering, engineers representing General Electric (our sponsor), and two students served as judges for the competition. The experiments were judged on the basis of scientific significance, size, safety, cost, and expected performance. Four experiments were chosen; an experiment to determine the effect of cosmic radiation on semiconductors, an orbital debris detection system, a fluxgate magnetometer experiment to measure magnetic moments of the Space Shuttle, and an experiment to measure the photoelectric yield of several different materials exposed to the space environment.

The effects of radiation on semiconductors experiment concentrates on gaining an understanding of the interaction mechanisms of cosmic radiation on semiconductors and how this relates to device failure. Four memory device technologies will be tested; SIMM, CMOS, NMOS, and GaAs.

The orbital debris experiment will detect and record space debris impacting with the Shuttle. Since the LDEF satellite was recovered attention in the space community has increased concerning the effect space debris will have on space platforms or spaceborne instruments. The detection system utilizes a piezoelectric sensor's output, that is digitized and filtered with a least mean square algorithm.

The fluxgate magnetometer experiment is designed to record the three dimensional magnetic field map of the Shuttle. The data from the three axis magnetometer will be used to determine the magnetic interference in the Shuttle from other equipment and from construction used in the Shuttle and cargo bay.

The photoelectric effect experiment is intended to measure the

photoelectric yield of several different materials. The data obtained will help determine which materials can detect ambient ionospheric plasma and minimize the effects of spacecraft charging. An electrometer will measure the currents from the photoelectron yield of eight samples.

THE EXPERIMENTS

Effects of Radiation on Semiconductors

The effects of radiation on semiconductor experiment will study the susceptibility of semiconductor memory to Single Event Upsets (SEUs) and permanent damage to the memory cells. The purpose of this experiment is to simultaneously test four types of memory device technologies at an accelerated temperature. Data will be written into the Memory Under Test (MUT) and left alone for one or two hours. The MUT will be kept at 50°C to evaluate the enhanced SEU susceptibility at the higher temperature. Then, the data in the MUT is read and the test time, total radiation dose, and any errors encountered are recorded in nonvolatile memory. The experiment consists of four main components; the test memory, nonvolatile storage memory, a solid state dosimeter, and a memory test sequencer.

The current plans call for the MUT to consist of a total of 64 kbytes of SRAM. There will be 2 kbytes of GaAs, 4 kbytes of SOS, 8 kbytes of NMOS, and the remaining 50 kbytes will be filled with commercial SIMM memory. The memory will be heated to 50°C for the entire flight by several positive temperature coefficient thermistor disks. The disks have relatively low resistance until the temperature reaches 50°C. Then the resistance rapidly increases, slowing and stopping the heating process. The test memory circuits will be arrayed near the top of the GAS canister to minimize the radiation shielding effects of the canister and Shuttle.

Nonvolatile memory will be used for Long Term Data Storage (LTDS). The memory will be 128 Kbytes of low power CMOS memory with battery back-up. The memory is designed with three separate 128 kbytes of storage area connected with the data and address lines in parallel. This makes a write-only triple redundant storage area for the test data.

A solid state dosimeter (Figure 1) is used to measure the total dose accumulated during the test and the dose rate in any particular 5 minute interval. The radiation detector is a semiconductor diode connected in a short-circuit current mode. Ionizing radiation in the PN junction generates current in the diode. The current is integrated until a threshold is reached. The integrator is then reset and two counters are incremented. One counter is used as a dose rate interval counter and the other counter for the measurement of total dose encountered in the experiment interval.

The possibility of an SEU causing a controller failure was a concern. The entire test could become useless if an SEU causes the controller to go astray and scramble the data in the LTDS. The memory test sequencer was designed as a single state control circuit constructed from conventional components, such as the 54LS series circuit technology, to minimize the possibility of radiation upsets. The circuit consists of two sequencers. Each sequencer is a counter with some or all of the counter outputs connected to the address inputs of a ROM. The ROM has 16 output data bits that are used to control data direction, data flow, test address and controller resets that occur in

the experiment. The sequence controller also includes a nonvolatile alarm clock. The clock has the time-of-day and date as well as a programmable alarm and 50 bytes of auxiliary nonvolatile memory.

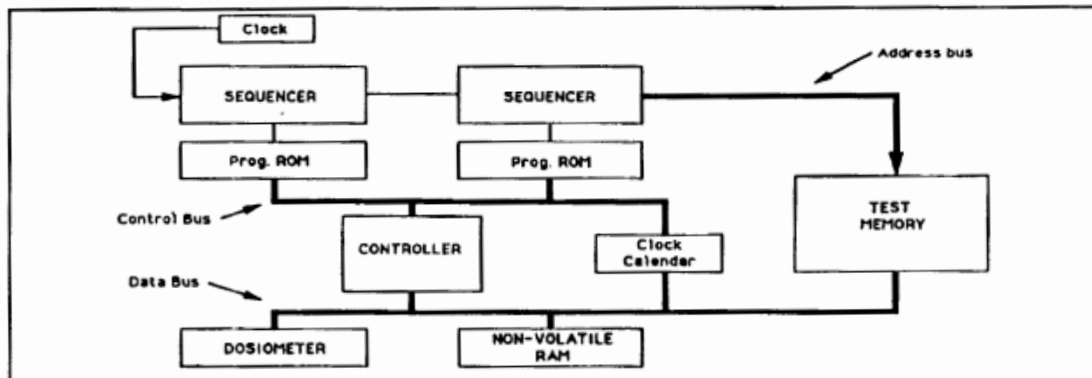

Figure 1. The Effect of Radiation on Semiconductors Experimental Block Diagram.

One sequence counter, sequencer A, initializes the test, writes the data in the MUT, reads and records the radiation dose rate and controls the time of the MUT check. The initialization procedure monitors the radiation dose for 5 hours to determine the minimum and maximum readings for these orbits. Then, the test data are written into the MUT and the alarm is set for one hour. When the alarm goes off, the radiation dose rate is measured and compared to the minimum and maximum values obtained before. If the orbit is near a maximum radiation region the memory test is not performed and the alarm is set another hour ahead. When one hour has elapsed and a low radiation dose rate is measured, or if two hours have elapsed since the last test, the control is passed to a second sequence counter, sequencer B.

Sequencer B writes a marker in the LTDS and tests each byte in the MUT four times for errors. Any error that is detected all four times is recorded in the LTDS. The error byte, the correct byte and the address of the error byte are recorded for each error detected. When all 64 kbytes are tested, the time and total dose are stored in the LTDS and the master reset is initialized.

After the mission, the data contained in the LTDS and clock will be analyzed. These data are triple redundant and should show the minimum and maximum radiation dose rates, total dose accumulated, the time of each test, and the location and type of error that has been detected.

Orbital Debris Detection System

The objective for the orbital debris experiment is to record the time and intensity of impacts on the Space Shuttle from debris encountered around the orbit. The total vibration (or noise) picked up by the sensor, an accelerometer, will come from three different types of vibrations: impacts, random noise (e.g. shuttle crew activity), and noise that has a sinusoidal dependence. The sinusoidal and random noises are considered background noise for this experiment.

One of the obstacles to this experiment is that the background

noise may, at times, mask the vibrations from the impacts. The main source of background noise normally comes from the motors, fans, and crew of the Shuttle. Because of the partly sinusoidal dependence of the unwanted noise as well as the fact that the amplitude, frequency or phase of this noise can not be known in advance, a digital adaptive filter approach is used. This digital adaptive filter is based on a least mean square (LMS) algorithm and is the heart of the software system.

The LMS algorithm estimates a signal (the impact) corrupted by noise and passes it through a filter. The filter will suppress the noise while keeping the impact signal relatively unchanged.

Now that we have a signal free of sinusoidal waves, we need a way to extract impacts from the random noise. We take the filtered signal, and run it through a "peak picker". The way this picker works is that we make a running average of 100 data points. The next point of data is compared to the running average plus a set threshold. If the data point is greater than the average plus the threshold, we conclude that it is an impact. In this case we record the amplitude of the signal and the time at which it occurred. If the data point is not a peak then it is not recorded. Each data point is then compared as it is obtained from the filter. By saving only the peaks, we have achieved a 1000/1 data compression ratio. This means that our experiment should be able to run for the entire shuttle flight.

A computer program was made to test the software on some simulated data. The results were positive. In Figure 2 we created a simulation of the output that the sensor would pick up. There are four different sources of noise with a sinusoidal dependence along with two impacts and random noise. Figure 3 shows an example of the signal of two impacts after the signal has been processed through the adaptive filtering code.

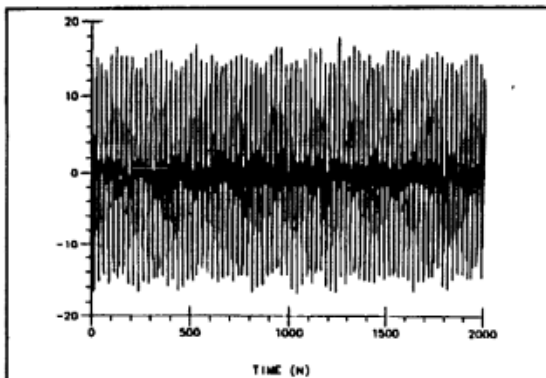

Figure 2. Simulated Output of Piezoelectric Sensor.

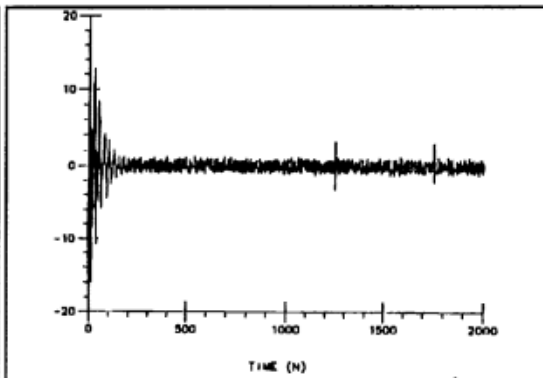

Figure 3. Processed Signal using LMS Algorithm.

The actual components needed for this experiment can all be purchased "off the shelf". Each component can be easily integrated to prepare the experiment. We have chosen certain data detecting, analyzing, and recording devices because of the power, cost, and reliability constraints. There are no moving parts in the device, with the exception of a calibration hammer, which does not affect the

design. We have chosen no disk drive recorders or the like because of their unreliability when exposed to adverse conditions.

The entire experiment will be able to function as a self-contained unit. This will be done so that, in the future, this design can be directly implemented into other orbital platforms or similar devices. However, for the GAS project, there are two exceptions. First, the piezoelectric device, which is the accelerometer used to pick up the vibrations, will be attached to the inside of the GAS canister. Secondly, our memory device will interface with the general recording device of the PSU GAS Systems Group for backup recording.

There are four basic components that need to be integrated for this experiment (Figure 4). The piezoelectric sensor, an analog to digital converter, the central processing unit, and a memory card or cards. All of the cards will be contained in a card cage. The converter will take the output of the sensor and transform it into data that can be used by the processor.

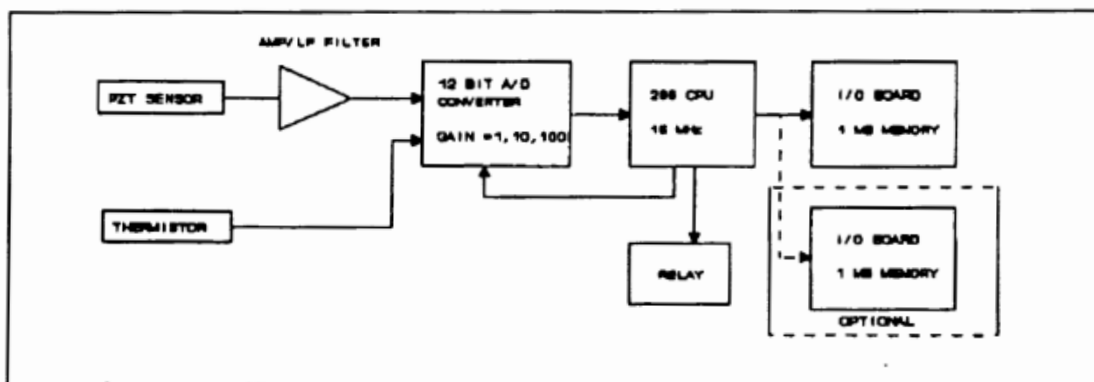

Figure 4. Orbital Debris Detection Experimental Block Diagram

The Fluxgate Magnetometer

The fluxgate magnetometer experiment is designed to record the three dimensional magnetic field map of the Shuttle. The three axis magnetometer's ability to detect changing magnetic fields is due to the nonlinear characteristics of the magnetometer's ferrite rods. The three pairs of ferrite rods (one pair for each orthogonal axis) are wrapped with three wire coils: a primary coil, a secondary coil, and a calibration coil.

The experiment begins when the accompanying drive circuitry (Figure 5) supplies a 2 kHz square wave reference signal. The signal is frequency divided to 1 kHz and sent through the primary coil, this will generate a magnetic field. Since the primary coils of each rod, in each pair of rods, are wrapped in the opposite sense, the magnetic fields in each primary coil are in opposing directions. The signal drives the ferrite core into saturation twice each cycle, changing the permeability of the core at a frequency, which is twice that of the primary current. [1] The magnetic flux in the core consists of the flux generated by the primary coil and that from the external surrounding magnetic field. The magnetic flux from the primary coil is produced at odd harmonics, since the permeability of the rods is

changing. The external surrounding magnetic field generates a magnetic flux at even harmonics because of the nonlinear properties of the core. Since the magnetic flux from the primary coils are in opposite directions, the net flux in the core from the primary coil equals zero. The flux in the secondary coil, then, is only from the external surrounding magnetic field.

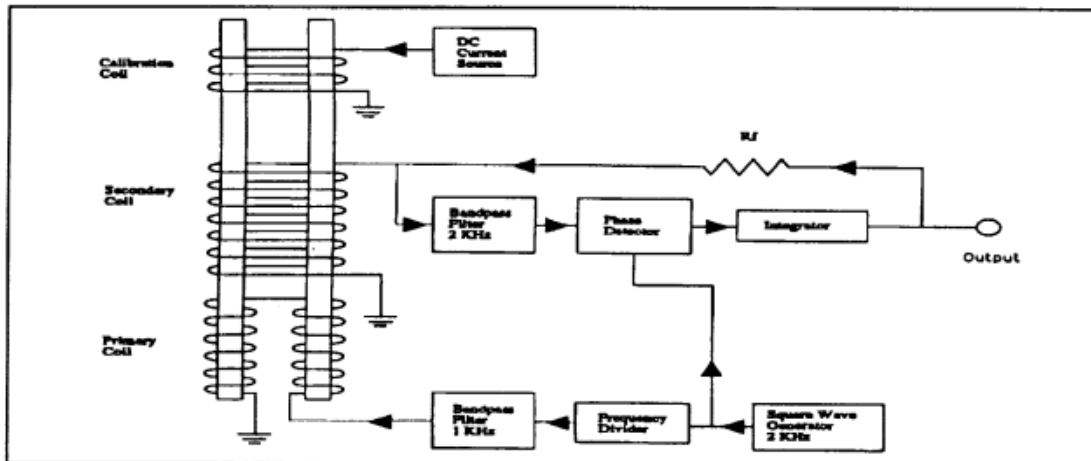

Figure 5. The Fluxgate Magnetometer

A calibration coil is used to cancel out a known portion of the signal due to the earth's magnetic field. The coil produces a magnetic field equal to and opposite the Earth's field. The equation for the magnetic field, B , produced is

$$B = \mu N I \quad \text{Equation 1}$$

where μ is the permeability of the rod, N is the number of turns of wire in the calibration coil, and I is the current passing through the calibration coil.

The magnetometer will be in equilibrium at all times. The voltage at the output of the integrator modifies the current through the feedback resistor leading to the secondary coil. This current produces an induced field in the rod that cancels the external surrounding magnetic field. The voltage across the feedback resistor is proportional to the external magnetic field, since

$$I = V / R \quad \text{Equation 2}$$

and the magnetic field, B , can then be determined by Equation 1.

The accompanying circuitry of the fluxgate magnetometer is also shown in Figure 5. The 2 kHz square wave signal generated is first frequency divided and then bandpass filtered to provide a sinusoidal signal into the primary coil. The voltage that arises in the secondary coil is then proportional to the surrounding magnetic field. The phase of the signal is compared with the reference signal to determine if the field is increasing or decreasing. The integrator modifies the voltage

across the feedback resistor to cancel out the changing external field.

The data recorded will consist of the direction and magnitude of the external magnetic field. This will be accomplished by recording the analog output from each axis's integrator. The output will be converted to digital data and stored every four seconds for five hours. In addition, the ambient temperature will be recorded every four seconds for five hours, since the temperature differences effect the core magnetization curve.

The experiment will be turned on by the GAS canister baroswitch after liftoff. Since the experiment would like to take measurements when the Space Shuttle performs a 360 degree roll maneuver, the magnetometer should be operating during the first five hours after liftoff. During the first hours of every Space Shuttle mission, rolls are executed in order to orient the Shuttle into its proper trajectory. Also, the three other experiments in our canister will be non-operational so the magnetic field produced by other experimental circuitry does not interfere with the magnetometer's measurements.

The data recorded from the magnetometer will be used to determine the magnetic interference in the Shuttle from other equipment and from construction used in the shuttle and cargo bay. The data will also be used to determine the magnetic properties of the shuttle.

The Photoelectric Effect Experiment

The purpose of measuring the photoelectric effect of materials in space is to obtain data on the photoelectric yield of several materials. The results from this experiment will be useful in design of ionospheric plasma probe experiments and in describing the local plasma interaction of satellites in orbit. The samples that will be used in this experiment are gold, aquadag, stainless steel, and aluminum. The reason why these materials were chosen is that all of them are common in spacecraft structures. For each of these materials, there will be a clean sample and a dirty (oxidized) sample, thus making a total of eight samples to be tested. The clean samples will have all surface oxides and organics removed through a chemical cleaning process. The eight samples as well as a solar cell will be placed on top of our structure to allow as much sun to impinge on the samples.

The photoelectric effect experiment will only operate when the shuttle bay is facing towards the sun. A special housing for the solar cell and the samples will be built in the shape of a cylinder. This housing will make sure the solar cell does not cause the system to run prematurely.

When the solar cell detects full illumination, the experiment will run as follows. The specimens, when illuminated, will emit photoelectrons which will be picked up by their respective electrometers. Each electrometer will amplify the current and give a voltage signal as an output. The voltages will be negative, so an inverting op amp is used to invert the signal and to set the gain. This signal will then be processed by the A/D converter for storage by the data system of the PSU GAS. A diagram of the circuit layout can be seen in Figure 6.

The electrometer needed for this experiment is one that can accept a wide range of currents (up to five orders of magnitude). For this

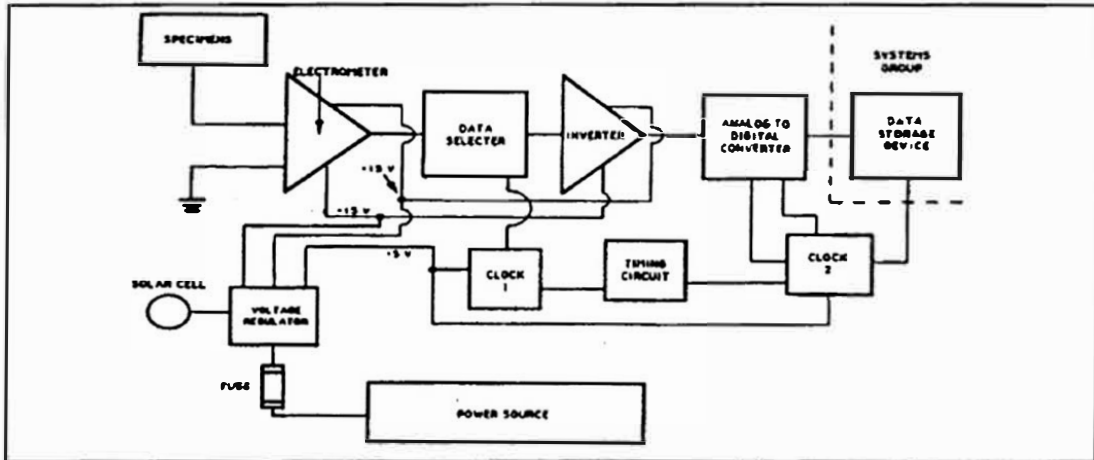

Figure 6. The Photoelectric Effect Experimental Block Diagram.

reason a logarithmic electrometer was chosen. A logarithmic electrometer has a range of up to 6 decades, which will allow the currents to be in the field of 100 pA to 10 μ A. Most of the design for the logarithmic electrometer was taken from Weihsing Liu's M.S. thesis. [2]

The data selector is an 8:1 analog multiplexer that is used to select a voltage output of one of the samples. Each sample has its own electrometer, so the selection insures that only one voltage is sent to the op amp and the converter to allow recording of these signals to the data storage device. An analog mux was chosen over its digital counterpart due to the analog's low power consumption.

The timing circuits box in Figure 6 contains two timers, one operating at 1 Hz and the other at 500 Hz. These timers control counters 1 and 2 respectively. The counters then select which specimen's data will be changed from analog to digital and eventually stored.

The experiment is designed to write data to memory once every second for the eight samples. The system will take two seconds before repeating the writing sequence, thus taking ten seconds to write the data to memory. The data system will be time stamped and will show which sample was recorded along with its photon count. If the solar cell indicates full solar intensity, the process will be repeated. The photoelectric effect experiment will select and convert data until there is no more space in memory or until the solar cell is no longer registering power.

While designing the circuit layout of the photoelectric effect, several parts received special consideration. Due to the wide variations of temperature in space, military specified components were chosen over commercial integrated circuitry. Also, low power Schottky chips were used in the design. As an example, the analog multiplexer chosen has a delay time of 1 μ s, and the A/D converter has a conversion time of 100 μ s. The PSU GAS data recorder requires 1 ms to write data, therefore the second timer is set at 500 Hz to allow data to be

transferred from the multiplexer to the data recorder without causing a data sample to be missed.

After the Shuttle mission, the data will be processed to provide a deeper understanding of which materials can be used to minimize spacecraft charging.

CONCLUSION

The four experiments will be integrated into a five cubic feet GAS canister. The entire operation will be activated by the baroswitch during liftoff. The magnetometer experiment will start taking data for the first five hours of flight. Then a timer will activate the other three experiments.

The four experiments are focused towards gaining a better understanding of the space environment. The semiconductor experiment will provide data on the susceptibility of different device technologies to the space radiation environment. The orbital debris experiment tests a system for the detection and recording of impacts to spaceborne systems. The fluxgate magnetometer provides information about the magnetic fields in the Shuttle bay. The photoelectric experiment will aid in determining what materials could be useful to minimize spacecraft charging.

It is expected that the engineering designs developed during Spring 1992 will be used to develop the experimental hardware for flight in Fall of 1993.

The experience and knowledge gained from this program will give valuable data on materials and operations in space and introduces students (Table I) to the challenge of design and construction of spacecraft systems.

Table I. Student Experimental Design Teams

Semiconductor Experiment	Orbital Debris	Fluxgate Magnetometer	Photoelectric Effect	Systems Group
D. Bower	M. Youssef	J. Costa	T. Dembiczak	T. Boris
T. Decarbo	J. Schwartz	C. Flotta	P. Olah	M. Makdad
T. Grosch	P. Stack	D. Smuck	B. Richie	R. Williams
B. Klus	J. Martone	G. Traub	M. Schaefer	J. Yurack
D. Nguyen	J. Szabados	W. Walker	B. Werner	K. Cha

Management Team: G. Evanisko, K. Dewitt, M. Weinel, and C. Stubner

REFERENCES

- [1]. Adolph S. Jursa, *Handbook of Geophysics and the Space Environment* (National Technical Information Service, Springfield, Virginia, 1985).
- [2]. Weihsing Liu, "A Logarithmic Electrometer for Rocket Probes" M.S. Thesis, The Pennsylvania State University.